

Port dimensions (DIN 3852-2)	
Tank port T1, T2	G 1/2"
Inlet port P1, P2	G 1/2"
Working ports A&B	G 3/8"
Port N	G 1/2"

TECHNICAL SPECIFICATION

Nominal Flow	50 l/min
Operating Pressure (max)	315 bar
Max. Backpressure	35 bar
Viscosity Range	10 - 300 cSt
Max. Level of Contamination	10 (NAS 1638) -/19/16 (ISO 4406-1999)
Internal Leakage	5ccm/min at 100bar, 40°C & 46cSt
Fluid Temp	-20°C to 80°C
Ambient Temp.	-40°C to 60°C
Seal Material	NRB
Fluid	Mineral Based Oil

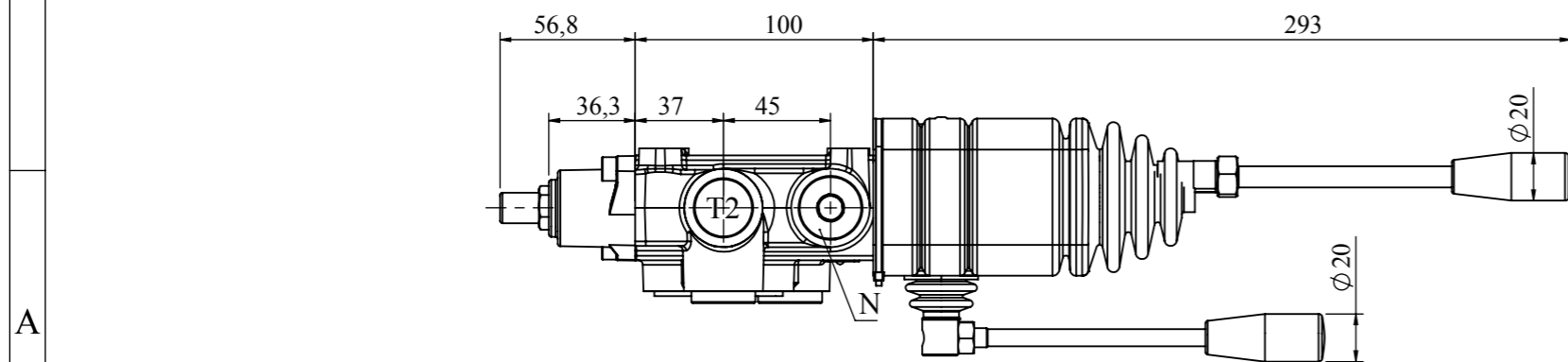

		Scale	Revision	Size	Weight
		1:3		A3	11.4 kg
Description:					
Number					
					ID