



Visit our homepage
for additional support
parker.com/pmde

Bulletin MSG30-8302-INST/UK

Speed Sensor Series F10/F11/F12 and V12/V14

Valid for sensor 3783883

Effective: March, 2023

Supersedes: November, 2022

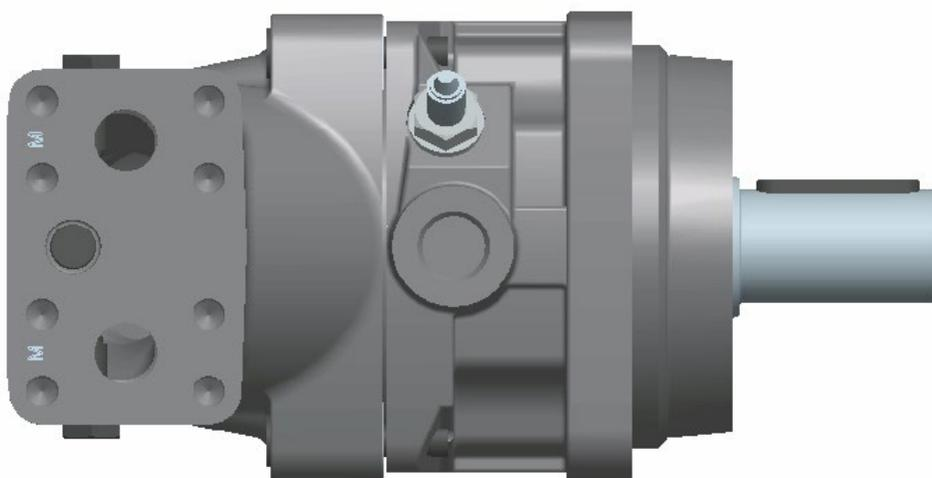

ENGINEERING YOUR SUCCESS.

General Information

The sensor consists of a ferrostat differential (Dual Channel) speed sensor and a seal nut. The sensor installs in a threaded hole in the F10, F12, V12 or V14 bearing housing, and in the F11 barrel housing. The sensor output is a 2 phase shifted square wave signal within a frequency range of 0 Hz to 15 kHz. The sensor detects both speed and direction of rotation. The sensor withstands high as well as low temperatures and is highly moisture protected (IP68).

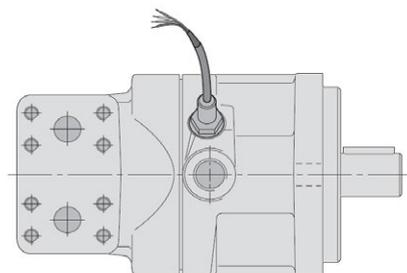

Technical Data

Power supply 10V to 30V protected against reverse polarity.

Current consumption Max 20 mA. (without load)

Signal output signals

- 2 phase shifted square waves
- Open collector outputs with 10 Kohm pull-up, I_{max} = -20 mA.

NOTE:

The outputs are short circuit proof and protected against reverse polarity.

Frequency Min 0 Hz max 15 kHz

Insulation Housing and electronics galvanically separated (500V/50Hz/1 min)

Operating temperature -40 to +125 °C [-40 to +255 °F]

Protection class IP68 (DIN 40050)

Sensor head pressure Max 25 bar [360 psi]

Weight (incl. cable) 0.15 kg [0.33 lb]

Sensing distance 0.1 to 2.0 mm; 1.0 recom. [0.004 to 0.08 in; 0.04 recom.]

Transistor NPN

Amplifier variant Variant; .02 SHW
Output 1: Speed
Output 2: Speed
Output type: Open Col.

CABLE

Material PUR casting
Length 1.0 m
No. of wires 4 (plus screen; transparent)
Wire area 4 x 0.34 mm²

Screen Stranded metal net (insulated from housing)

NOTE: Screen must be connected to 0 V (zero volt) power supply.

Bending radius Min 25 mm [1 in]

| Frame Size | No. of pulses/rev. |
|---------------------------------------|--------------------|
| F10/F11-6, -10, -12, -14, -19 | 5 |
| F10/F12 (30-125) | 35 |
| F12 (152-182) | 40 |
| F12-250 Up to serial no. 201602230409 | 64 |
| F12-250 From serial no. 201602230410 | 36 |
| V12/V14 (ISO, SAE and Cartridge) | 36 |
| V12 -060 Cartridge | 9 |

Connection

Sensor wires are susceptible to radiated noise. Therefore, the following should be noted:

- Uninterrupted screened 4 wire cable must be used and the screen only connected to the appropriate instrument screen input terminal or 0V. Connections to power earth are not advisable.
- The sensor wires must be installed as far away as possible from electrical machines and must not run in parallel with power cables in the vicinity.

The maximum cable length that can be utilized is dependent on sensor voltage, how the cable is installed, and cable capacitance and inductance. It is, however, always advantageous to keep the distance as short as possible. The sensor cable supplied can be lengthened via a terminal box located in an IP20 protected connection area (per DIN 40050).

Contact Pump & Motor Division Europe for recommendations.

Connections and Pulse Diagram:

Direction of rotation

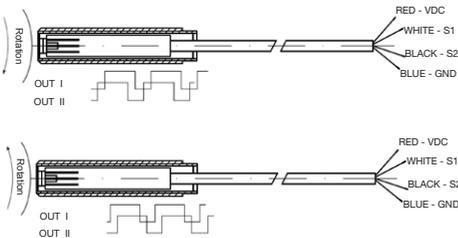

Installation information

As the sensor has a built-in differential Hall effect device, the sensor housing must be aligned according to the drawing (Fig. 1 & 2) of the Speed Sensor Installation picture. If it is not, the sensor may not function properly and noise immunity decreases. The sensor is non-sensitive to oil and the stainless steel housing withstands hazardous environment conditions.

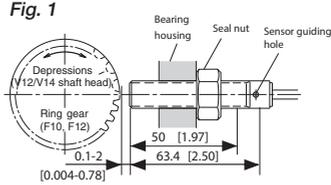

Speed sensor installation, F12, V12, V14

Installation Procedure

- Install the sensor in the threaded hole (M12x1) of the **F10/F12/V12/V14** bearing housing; turn the sensor until its head just touches the ring gear teeth (F10/12) or the shaft head (F12-250/V12/V14); refer to the installation drawing above.
- On ***F10/11** the **pistons positions must be known** before mounting the sensor. Install the sensor in the threaded hole (M12x1) of the F11 barrel housing; turn the sensor until its head just touches the piston.
- When mounting the sensor in the threaded hole be sure that you also rotate the cable so the cable not get twisted.
- Back off the sensor one turn (counter clockwise).
- If required, back it off further until the sensor guiding hole centerline is either as shown in Fig. 1 & 2 or 180° opposite.
- Tighten the seal nut; max 12 Nm (100 lb in). Be sure that the position of the guiding hole centerline still is correct.
- Connect the electrical wires as shown in the schematic. Please note the instructions on page 1 regarding screening.
- If you only use one signal, we recommend you to use S2 cable. Cut S1 cable and isolate.

Fig. 2

* F11: -6, -10, -12, -14, -19

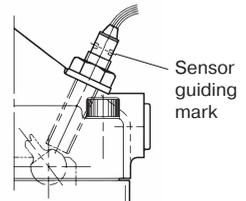

Position notification regarding Machinery Directive 2006/42/EC:

Products made by the Pump & Motor Division Europe (PMDE) of Parker Hannifin are excluded from the scope of the machinery directive following the "Cetop" Position Paper on the implementation of the Machinery Directive 2006/42/EC in the Fluid Power Industry.

All PMDE products are designed and manufactured considering the basic as well as the proven safety principles according to:

- ISO 13849-1:2015
- SS-EN ISO 4413:2010

so that the machines in which the products are incorporated meet the essential health and safety requirements.

Confirmations for components to be proven component, e. g. for validation of hydraulic systems, can only be provided after an analysis of the specific application, as the fact to be a proven component mainly depends on the specific application.

Christian Jäger

General Manger

Pump & Motor Division Europe



WARNING – USER RESPONSIBILITY

FAILURE OR IMPROPER SELECTION OR IMPROPER USE OF THE PRODUCTS DESCRIBED HEREIN OR RELATED ITEMS CAN CAUSE DEATH, PERSONAL INJURY AND PROPERTY DAMAGE.

This document and other information from Parker-Hannifin Corporation, its subsidiaries and authorized distributors provide product or system options for further investigation by users having technical expertise.

The user, through its own analysis and testing, is solely responsible for making the final selection of the system and components and assuring that all performance, endurance, maintenance, safety and warning requirements of the application are met. The user must analyze all aspects of the application, follow applicable industry standards, and follow the information concerning the product in the current product catalogue and in any other materials provided from Parker or its subsidiaries or authorized distributors.

To the extent that Parker or its subsidiaries or authorized distributors provide component or system options based upon data or specifications provided by the user, the user is responsible for determining that such data and specifications are suitable and sufficient for all applications and reasonably foreseeable uses of the components or systems.

Offer of Sale

Please contact your Parker representation for a detailed "Offer of Sale".



Parker Hannifin Manufacturing Sweden AB

Pump & Motor Division Europe

Flygmotorvägen 2

461 82 Trollhättan

Sweden

Tel. +46 (0)520 40 45 00

www.parker.com/pmde

MSG30-8302-INST

Art. No 3784073-01

© Copyright 2023

All rights reserved