

SEZIONE A-A

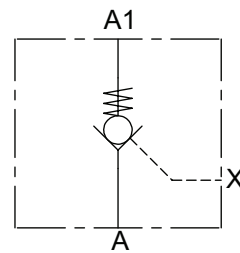

Portata Max Max Flow Rate	50 l/min
Pressione di lavoro max Max working pressure	350 bar
Pressione di apertura Cracking pressure	10 bar
Rapporto di pilotaggio Pilot ratio	3.4 :1
Cavità Cavity	N330000
Temperatura di lavoro Operating temperature	-25 ÷ +80 °C

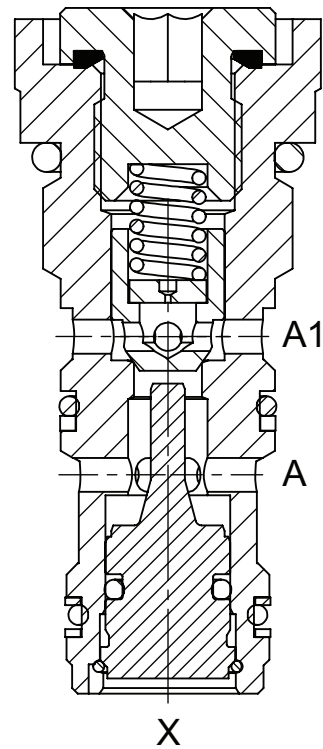

OGGETTO: VALVOLA DI BLOCCO A CARTUCCIA

Sigla

Foglio  
Foglio 1

Scostamenti limite per dim. lineari:  
CLASSE:m UNI EN 22768-1

Scostamenti limite Toll. Forma:  
CLASSE:K UNI EN 22768-2

Scostamenti limite per dim. lineari getti  
CLASSE:CT8 UNI ISO 8062

Gruppo

Prototipo/Sost. il cod.  
RS09084600

Diseg:  
PM

Data  
01/10/2009



CODICE

Mod.

Approv.  
PM

Data  
10/10/2011

Scala  
1:1

07231241N0

3